

# PRODUCT INFORMATION AIR LEAK TESTER

Compact & Specialized in Small-volume Products  
Big LCD Screen Displays Wealth of Information



## LS-1813 AIR LEAK TESTER

### Features

- Pneumatic Circuit Specialized in Small-volume Products
- Big LCD screen
- Mastering Drift Compensation
- Intelligent Pneumatic Circuit
- Graphic Display of Max. 1000 Data
- NR (Noise Reduction)
- Auto Self-Diagnosis
- Automatic Measurement of Equivalent Internal Volume
- Serial Communication Port

### ■ Features

Display	Full-dot LCD screen with backlight	
	Data automatically saved when turned OFF (uses nonvolatile RAM)	
Intelligent Pneumatic Circuit	Sensitivity check, Air valve operation check	
Charge Hold	Keep pressurizing in order to find out leakage spot	
Alarm Setting	2-step alarm setting: Work Large/Small NG (HH/Hi-NG), Master Large/Small NG (LL/Lo-NG)	
Noise Reduction	In Hi-NG to HH-NG range, conduct re-detection. Setting of extended detection times. Signal output during operation (For cycle over release)	
Calibration	Measurement of Leak coefficient K(Ve) (Equivalent internal volume DPS offset and span calibration Test Pressure offset and span calibration	
Drift Compensation	Mastering, Auto drift compensation	
Self Diagnosis	Check of Air valve operation, Sensor offset, CPU operation etc	
Sensor protection	Air blow at exhaust time	Automatic cleaning of pneumatic circuit at every test
	External exhaust valve	External exhaust valve is required (option)

Exhaust Interference Control	External control of exhaust timing after each test	
Graphic Display	Mastering data, Sampling data	
Selection of Unit	Leak	mL/min, mL/s, Pa, kPa, (Non SI unit: mmH <sub>2</sub> O etc)
	Test Pressure	kPa, MPa (Non SI unit: kg/cm <sup>2</sup> , PSI, mmHg etc)
	Equivalent Internal Volume	ML, L (Non SI unit: in <sup>3</sup> , ft <sup>3</sup> )
Number of Channel	32 (0~31), Channel copy	
Judgment Mode	<u>Judge when detection finish</u> /Judge when setting value met/Others	
Serial Communication	Format selection ( <u>I/ID/T/P</u> ), Baud rate change	
Other Display	Error comment, Index, Help, I/O monitor, HSI of leak DP (analog bar), Work No# & OK·NG counter	
Mastering Setting	Date, Interval & number of times, Waiting time, Number of limit over time, Default of compensation, Mastering limit, Number of loops, Auto drift compensation limit, Number of samples	
Other Setting	Test pressure limit (Upper & Lower), Counter clear Stop signal ( <u>Normal open/Normal close</u> ) Draft clear NG start command ( <u>Stop command unnecessary before test</u> /Necessary), Countermeasure of Exhaust interference (With/Without)	

※Underline indicates the standard setting at delivery time

## ■ Specification

Differential Pressure	Minimum Reading	Standard: 0.1 Pa (If unit is kPa, minimum reading is 0.001kPa)
	Display Range	Standard: ±999Pa (If unit is kPa, display range is ±1.5kPa)
	Reading Accuracy	Standard: 0 to ±1000Pa
	DP Range	Standard: ±2000Pa
	Allowable Pressure	5 MPa
Display Unit	Test Pressure	kPa, MPa, (Non SI unit: kg/cm <sup>2</sup> , PSI, mmHg etc)
	Leak Rate	mL/min, mL/s, m <sup>3</sup> /min, Pa, kPa, (Non SI unit: mmH <sub>2</sub> O, mmHg, inH <sub>2</sub> O)
Display Digit		3 digits (floating-point), Sampling rate 10times/sec
Leak Rate Limit		Standard: ±999.999Pa Max (If unit is kPa, leak rate limit is ±1kPa max)
Number of channels		32ch(0 to 31)
Timer Setting		999.9 sec (Resolution 0.1sec)
Power Supply		AC100 to 240V±10%, 50/60Hz, 100VA max (Attached cable can be used if power supply is less than AC125V) (Power supply of Internal solenoid: DC24 V)
Test Pressure Source		Clean air whose pressure is sufficiently higher than test pressure
Pilot Pressure Source		Clean air regulated from 300 to 700kPa

Tubing Port Inner Diameter	Rc1/4(Test pressure source, WORK and MASTER ports) 6mm One-touch joint (Pilot pressure source) (Tubing connected to Pressure Source in advance with M,L,MR type.)	
CPU	16 BIT CPU	
Ambient Temperature	5 to 40 °C	
Humidity	80 %RH or less, no condensation	
Weight	Approx. 9.5 kg	
Serial Communication Port (Output format can be selectable)	I/F fixed length output ID/F fixed length output (Default)	Leak rate data and parameters are simultaneously output
	T/F fixed length output	Leak rate data is output. Same with Cosmo product DF/MC/DC-720
	P/F Printer format	(Data output) Leak rate data and a list of parameters are output  (Setting output) Parameters of all setting screen
Standard Accessories and Components	Quick mounting brackets, Connector for interface ports, Power code (3m), Inspection record and Operation manual	

## ■ Model LS-1813-①②-③

①	Pneumatic Circuit	AS1: Intelligent I pneumatic circuit for small-volume WORK (Standard) AS01: Pneumatic circuit for minute-volume WORK (Option)	
②	Pressure Range	Regulator	L: 10 to 80kPa M: 50 to 700kPa, V: -5 to -100kPa (L02: 5 to 20kPa will be released soon)
		Electro-pneumatic Regulator	LR: 10 to 80kPa MR: 50 to 700kPa VR: -10 to -100kPa
③	Option	W: Stop valve check switch Q: CE-compliant model S: PNP output	

## ■ External Appearance

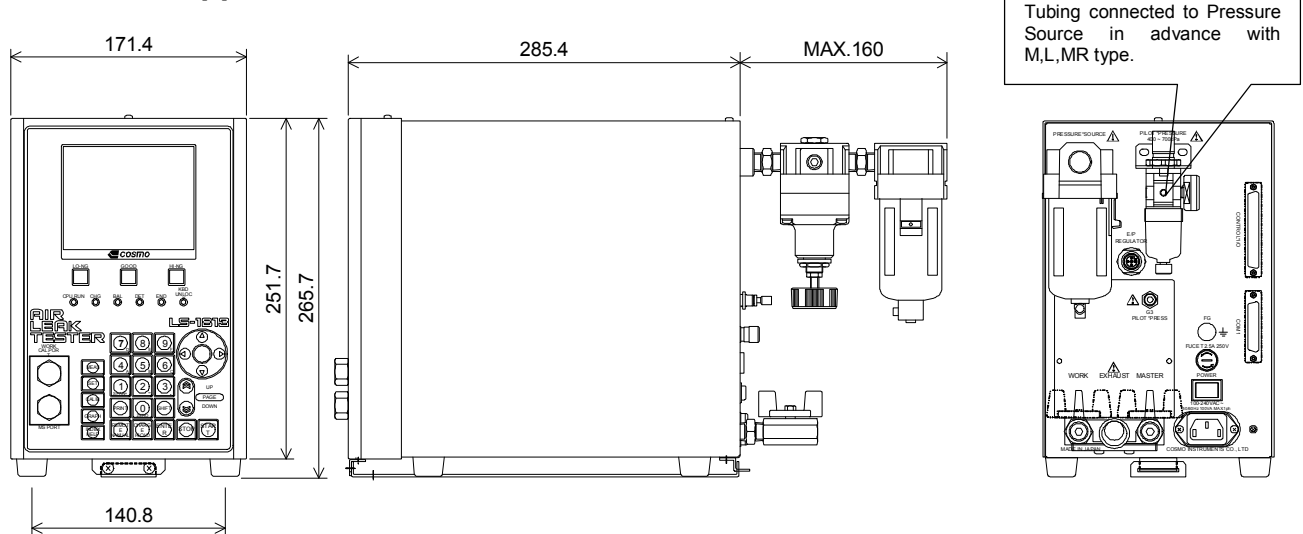

※Contents of this catalog is correct as of Sep 2009. Please note that any details shown above are subject to change without notice

**COSMO INSTRUMENTS CO., LTD.**  
2974-23 Ishikawa Hachioji, Tokyo Japan  
Phone: +81-(0)42-642-1357  
Fax: +81-(0)42-646-2439

<http://www.cosmo-k.co.jp/>

**China**  
**U.S.A.**  
**Korea**  
**Taiwan**  
**Malaysia**  
**Thailand**  
**Indonesia**  
**India**  
**Australia**  
**U.K.**

Cosmo (Shanghai) Trading Co., Ltd.  
Cosmo Solutions Technology Inc.  
Cosmo Korea Co., Ltd.  
Diafriend Corp.  
Wave Electronics & electrical System Sdn. Bhd.  
Cosmowave Technology Co. Ltd  
Wave Electronics & electrical System Sdn. Bhd.  
Cosmo Instruments Co., Ltd. India Liaison Office  
Industrial Research Technology Pty. Ltd.  
Fletcher-Moorland Limited

Phone: +86-(0)21-6575-6880  
Phone: +1-248-488-2580  
Phone: +82-(0)32-623-6961  
Phone: +886-(0)2-27121050  
Phone: +60-(0)3-51626677  
Phone: +66-(0)2-7361667  
Phone: +62-(0)21-42900043  
Phone: +91-(0)124-2577627  
Phone: +61-(0)3-9469-6888  
Phone: +44-(0)1782-411021

LS-1813-985B1-A